

ARTICULO: 2835

Junta de expansión metálica, extremos Bridados DIN. Metal Expansion Joint, DIN Flanges ends.

Características

1. Junta de expansión metálica.
2. Extremos bridados según DIN PN 16.
3. Cuerpo de Acero Inoxidable AISI 304.
4. Bridas de Acero al Carbono galvanizados.
5. Vibración reducida.
6. Tirantes limitadores de movimiento para evitar roturas por exceso de compensación.
7. Presión de trabajo máxima 16 Kg / cm².
8. Temperatura de trabajo -40 °C / + 300 °C.
9. Camisa interior para evitar excesivas pérdidas de carga y posible acumulación de producto en el interior del fuelle el cual le reduce la capacidad de trabajo.

Features

1. Metal Expansion Joint.
2. Flanges ends according DIN PN 16.
3. Body made of Stainless Steel AISI 304.
4. Galvanized carbon steel flanges.
5. Reduced vibration.
6. Limit rods are used to protect from movements in excess.
7. Max. Working pressure 16 Kg / cm².
8. Working temperature -40 °C / +300 °C.
9. Inner Sleeve to avoid excessive load losses and possible product accumulation inside the bellows which reduces him the work capacity.

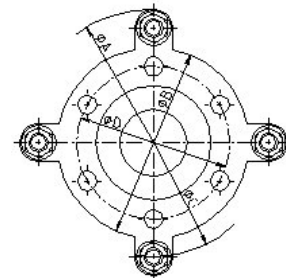
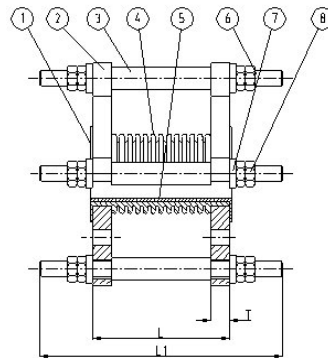

Nº	Denominación/Name	Material	Acabado Superficial/Surface Treatment
1	Junta / lap Joint	Acero Inox. 304 / S.S. 304	-----
2	Brida / Flange	Acero Carbono / Carbon Steel	Galvanizado / Galvanized
3	Tubo / Pipe	Acero Carbono / Carbon Steel	Galvanizado / Galvanized
4	Fuelle / Bellows	Acero Inox. 304 / S.S. 304	-----
5	Camisa interior / Inner Sleeve	Acero Inox. 304 / S.S. 304	-----
6	Tirante / Rod	Acero Carbono / Carbon Steel	Galvanizado / Galvanized
7	Arandela / Washer	Goma / Rubber	-----
8	Tuerca / Nut	Acero Carbono / Carbon Steel	Galvanizado / Galvanized

DIMENSIONES GENERALES / GENERAL DIMENSIONS

Ref	Medida/ Size	DN	PN	Dimensiones/Dimensions (mm)					Peso/Weight (Kg)
				N° Conv.	Ø A	Ø B	Ø C	Ø D	
2835 09	2"	50	16	11	235	165	195	125	7.15
2835 10	2 1/2"	65	16	11	255	185	215	145	8.95
2835 11	3"	80	16	12	270	200	230	160	9.80
2835 12	4"	100	16	12	305	220	250	180	12.65
2835 13	5"	125	16	11	360	250	287	210	18.45
2835 14	6"	150	16	12	390	285	322	240	24.35
2835 16	8"	200	16	12	430	340	377	295	28.90

Ref	Medida/ Size	DN	PN	Dimensiones/Dimensions (mm)				
				Tirantes / Rods		L	L1	T
				E - Ø F				
2835 09	2"	50	16	4 - 18	3 x M12	150	225	16
2835 10	2 1/2"	65	16	4 - 18	3 x M12	150	225	18
2835 11	3"	80	16	8 - 18	3 x M12	150	225	18
2835 12	4"	100	16	8 - 18	3 x M12	150	225	20
2835 13	5"	125	16	8 - 18	4 x M16	150	245	20
2835 14	6"	150	16	8 - 23	4 x M16	200	295	23
2835 16	8"	200	16	12 - 23	4 x M16	200	295	23

Parámetros de compensación / Performance parameter:

Referencia / Reference	DN	Presión de Trabajo / Working Pressure (Kg/cm ²)	Temperatura de trabajo / Working Temperature (°C)	Compensación Axial en diferentes ciclos de trabajo / Axial compensation in different cycle			Spring Rate (Kg/mm)	Effective Area (cm ²)
				1000 cycle	>=5000 cycle	>= 10000 cycle		
2835 09	50	16	300	15	9	7	28	27,3
2835 10	65			17	9	7	33	47,3
2835 11	80			17	9	7	34	58
2835 12	100			16	9	6	45	98,5
2835 13	125			14	8	6	63	160,6
2835 14	150			18	10	8	76	228,3
2835 16	200			26	15	12	56	366,4

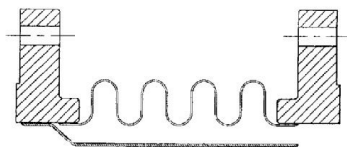

Detalle de Camisa interior /
Inner Sleeve detail

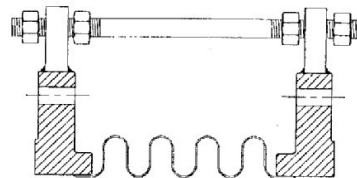

Detalle de Tirante limitador /
Limit Rods detail