

## **Art.2850 Controlador de Caudal** **Art.2850 Flow Switch for Fluids**

### **Características**

Dispositivo de seguridad para la detección y transmisión a distancia de la falta de caudal de todos los líquidos no corrosivos, tales como agua, aceite, etc.

1. Protección de bombas contra el descenso o ausencia de caudal.
2. Control secuencial de actuación de bombas
3. Arranque automático de bombas auxiliares y máquinas.
4. Actuación sobre sistemas de alarma o señalización
5. Desconexión de equipos de proceso con refrigeración por agua, cuando el flujo queda interrumpido
6. Apaga los quemadores cuando falla el suministro de aire en el serpentín de calentamiento
7. Desconecta máquinas herramientas si falla el caudal de aceite de refrigeración

### **Features**

Safety device for detection and distance transmission in case of lack of flow of any non-corrosive liquid, such as water, oil, etc.

1. Pumps protection in case decrease or lack of flow occurs.
2. Sequential control of pumps performance.
3. Self-starting of auxiliary pumps and machines.
4. Action on alarm and signalling systems.
5. Disconnection of water flow cooling processes and equipment when flow is interrupted.
6. It switches off the sprayers when air supply fails in the heating coil.
7. Disconnects machine tools if freezing oil flow fails.

### **INSTALACION**

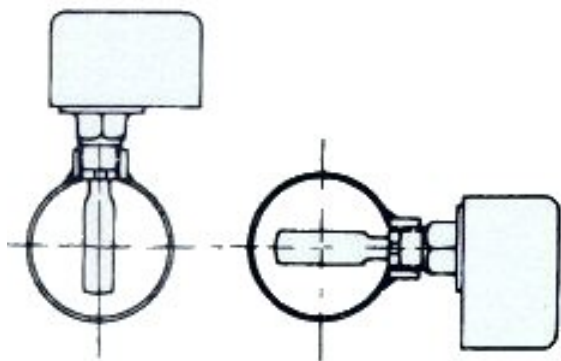

### **INSTALLATION**

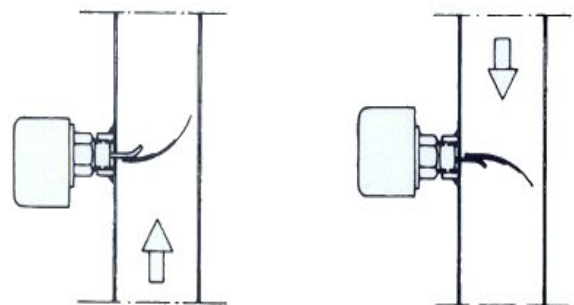

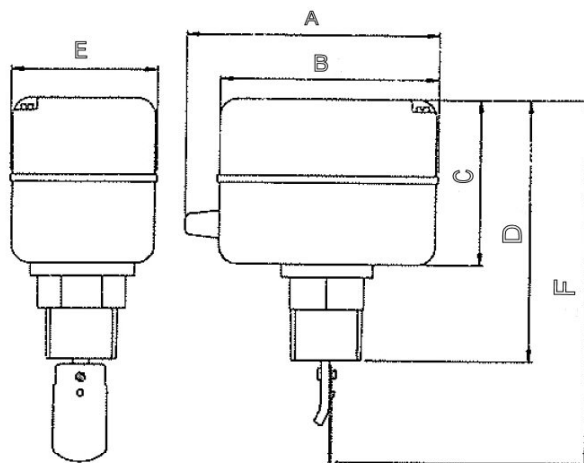

Ref	Medida /Size	PN	Dimensiones / Dimensions (mm)							Peso/Weight (g)
			R	A	B	C	D	E	F	
2850 06	1"	10	1"	130	108	77	122	63	158	800

### Datos Técnicos

Conexión:	1" Gas rosca macho
Presión Máxima de trabajo:	10Kg/cm <sup>2</sup>
Temperatura máx. fluido:	110 °C
Temperatura máx. ambiente:	-20 / 80 °C
Máx. Intensidad:	10 A á 250V
Conmutador unipolar	
Índice de Protección:	IP-54

### Technical Date

Connection:	1" Gas male screw
Max. Working Pressure:	10Kg/cm <sup>2</sup>
Max. Flow temperature:	110°C
Max. Room temperature:	-20/80 °C
Max. Intensity:	10 A to 250V
Single-way switch.	
Protection Standards:	IP-54

Componentes / Parts	Material / Material
Caja / Box	Acero Pintado / Coated Steel
Micro ruptor / Micro switch	10A – 250 V
Fuelle paleta / Water tightness bellows	Aleación cobre zinc / Alloy Copper and zinc
Racor unión / Nipple	Latón / Brass
Eje de paleta / Stem	Latón / Brass
Paleta / Blade	Acero Inox / Stainless steel
Tornillo regulación / Adjustment screw	Acero / Steel
Tornillo fijación / Screw fixation	Acero / Steel
Muelle resorte / Spring	Acero / Steel

## AJUSTE DEL FLUJO / FLOW RATE SETTING:

El máximo caudal se obtiene aflojando el tornillo indicado en el croquis. El controlador de flujo viene de fábrica con el tornillo apretado al máximo (caudal mínimo). La siguiente tabla muestra el rango de caudales en función del tamaño de la tubería y de la paleta instalada.

*Fully loosen the screw shown in the picture to have maximum flow rate setting. The flow switch is supplied ex-factory with the setting screw fully tightened (minimum setting). The following table gives the flow range in relation to the pipe diameter and the blade length.*

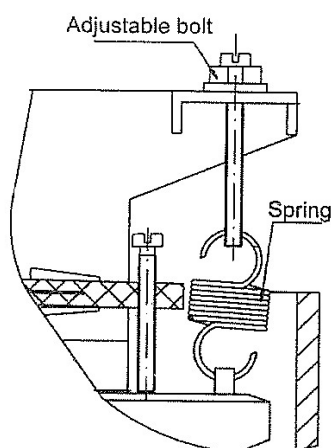

## CABLEADO / WIRING DIAGRAM:

- Marrón+Azul es normalmente abierto (los contactos conectarán ante la acción)
- Brown+Blue is normally opened (the contacts will connect when action)
- Marrón+Negro es normalmente cerrado (los contactos desconectarán ante la acción)
- Brown+Black is normally closed (the contacts will disconnect when action)

Marrón --- COM

Azul ----- N.A.

Negro ----- N.C.

A/V ----- Tierra

## TABLA DE CAUDALES DE INTERVENCIÓN / INTERVENTION FLOW RATE

DIMENSIONES DIMENSIONS		REGULACIÓN DISTENDIDA (MIN) (MIN) DISTENDED ADJUSTMENT (m <sup>3</sup> /h)		REGULACIÓN APRETADA (MAX) (MAX) TIGHTENED ADJUSTMENT (m <sup>3</sup> /h)	
"Ø" TUBERÍA PIPE	"L" PALETA BLADE (mm)	ABRE CONTACTO SWITCH ACTION	CIERRA CONTACTO SWITCH RETURN	ABRE CONTACTO SWITCH ACTION	CIERRA CONTACTO SWITCH RETURN
1"	34 (1)	1.3	0.8	2.0	1.6
1 1/4"	34 (1)	1.2	0.7	2.6	2.0
1 1/2"	57 (2)	1.6	1.0	3.3	2.6
2"	57 (2)	3.2	2.2	6.6	6.1
2 1/2"	88 (3)	4.2	3.2	8.0	7.0
3"	88 (3)	6.3	4.7	12.0	11.0
4"	88 (3)	8.5	6.0	18.0	17.0
5"	167 (4)	13.1	9.0	27.0	25.0
6"	167 (4)	17.2	12.0	33.0	31.0
8"	167 (4)	47	39.0	94.0	91.0

